

Cast-in lifting hoop

Type AS 0.8 - AS 25.0



Installation and Application Instruction

Our products from the division BUILDING SOLUTIONS

SERVICES

- » On-site tests -> we ensure that your requirements are properly covered by our planning.
- » Test reports -> for your safety and documentation.
- » Trainings -> the knowledge of your employees from planning and production is enhanced by our experts on site, online or via webinar.
- » Planning support -> latest design software, planning documents, CAD data and much more can be downloaded any time from www.philipp-group.de.

HIGH DEMANDS ON PRODUCT SAFETY AND PRACTICALITY

- » Close cooperation with notified bodies and - if necessary - approval of our solutions.

TECHNICAL DEPARTMENT

- » Our expert-team will support you at any time during your planning phase with detailed advice.

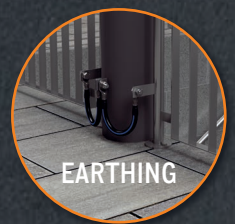
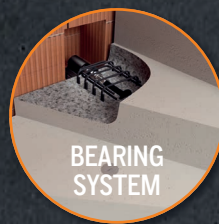
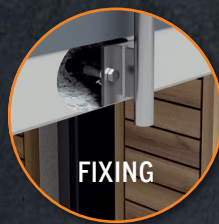
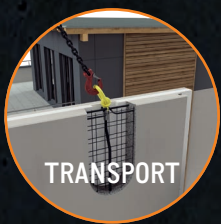

CONTENT

GENERAL PRODUCT INFORMATION	Page	4
Dimensions	Page	4
Materials, Marking, Corrosion	Page	5
Storage of Cast-in lifting hoops	Page	5
Concrete	Page	5
CAST-IN LIFTING HOOPS IN BEAMS AND CONCRETE ELEMENTS SIMILAR TO WALLS	Page	6
Element thicknesses, centre and edge distances	Page	6
Permissible load directions	Page	6
Reinforcement	Page	7
CAST-IN LIFTING HOOPS FOR NARROW BEAMS	Page	8
Element thicknesses, centre and edge distances	Page	8
Permissible load directions	Page	8
Reinforcement	Page	9
INSTALLATION / SAFETY	Page	10
Installation	Page	10
Safety notices	Page	10
Storage of the precast units	Page	11

PHILIPP Cast-in lifting hoop

GENERAL PRODUCT INFORMATION

The Cast-in lifting hoop is part of the PHILIPP Transport anchor system and complies with the VDI/BV-BS Guideline "Lifting anchors and lifting insert systems for precast concrete elements" (VDI/BV-BS 6205). The use of Cast-in lifting hoops requires the compliance with this Installation and Application Instruction as well as the General Installation Instruction.

Cast-in lifting hoops are designed for the transport of precast concrete units only. Multiple use within the transport chain (from production to installation of the unit) means no repeated usage. A repeated use (e.g. ballasts for cranes) is not allowed.

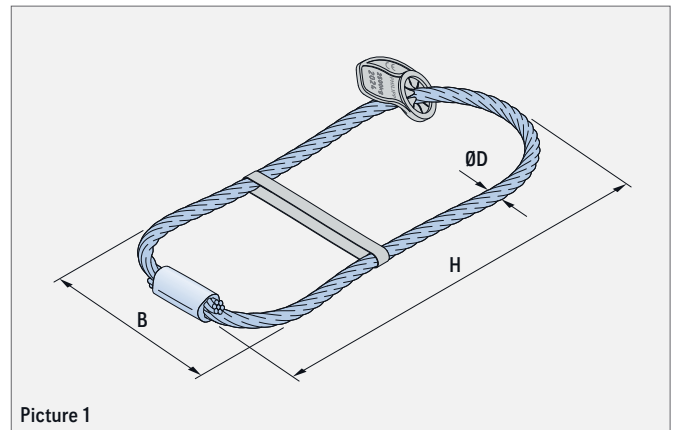

Picture 1

TABLE 1: DIMENSIONS

Ref. no.: galvanised	Type	Dimensions			Colour code
		H ① (mm)	B ① (mm)	ØD ② (mm)	
442008	○ AS 0.8	235	95	6	Pure white
442012	● AS 1.2	235	95	7	Flame red
442016	● AS 1.6	235	100	8	Light pink
442020	● AS 2.0	270	115	9	Pastel green
442025	● AS 2.5	310	135	10	Jet black
442040	● AS 4.0	340	150	12	Emerald green
442052	● AS 5.2	365	165	14	Curry
442063	● AS 6.3	380	180	16	Light blue
442080	● AS 8.0	440	205	18	Silver grey
442100	● AS 10.0	515	245	20	Claret violet
442125	● AS 12.5	570	270	22	Sulfur yellow
442160	● AS 16.0	605	286	24	Blue lilac
442200	● AS 20.0	730	345	28	Beige
442250	● AS 25.0	780	375	32	Clay brown

① Dimensions H and B are standard values and can vary depending on the position of the fixation strap.

② Rope diameter ØD is a standard value and can vary depending on the wire rope construction.

Cast-in lifting hoops with higher working load limits (AS 28.0 bis AS 95.0) are described in a separate data sheet. Depending on the individual application it might be necessary to contact our technical department before use.



FURTHER QUESTIONS

If you have further questions, please have a look at our website www.philipp-group.de or call our technical department under +49 6021 40 27-318 resp. send an email to technik@philipp-gruppe.de.

GENERAL PRODUCT INFORMATION

MATERIALS

The Cast-in lifting hoop consists of a galvanised steel wire rope that is formed into a loop by pressing the rope ends together using a press clamp.

MARKING

In order to identify the types of the Cast-in lifting hoop visually they are marked with a coloured tag. This tag must also be visible at the segment sticking out after concreting. With its fins the tag guarantees an easy fixing to this part of the Cast-in lifting hoop sticking out of the element.

Following data are given on the tag:

- » Manufacturer (PHILIPP)
- » CE mark
- » Max. load bearing capacity (e.g. 2500 kg)
- » Year of manufacturing (e.g. 2024)
- » Illustration of the installation dimensions

EC-DECLARATION OF CONFORMITY

The EC Declaration of Conformity (DoC) of the Cast-in lifting hoop can be downloaded from our website www.philipp-group.de or is available on request.

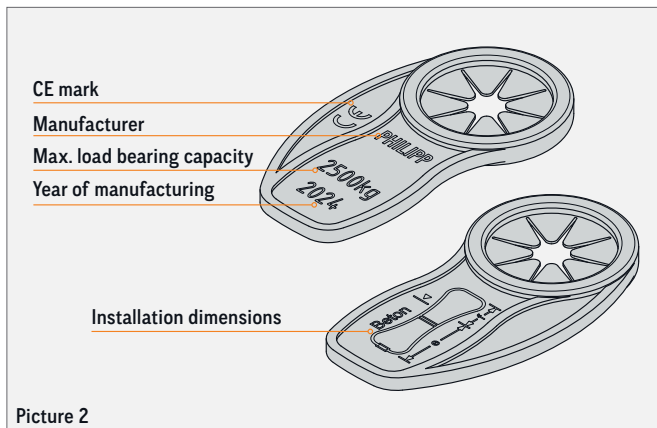

CORROSION

For concrete with an increased chlorine equivalent the use of a Cast-in lifting hoop with aluminium ferrule is not recommended. For this application a Cast-in lifting hoop with a steel ferrule is more suitable and can be delivered by PHILIPP on request.

An increased chlorine equivalent exists if the values given in the standard EN 206-1 are exceeded.

NOTE!

The aluminium ferrule used with Cast-in lifting hoops must not be placed near-surface of the concrete element. The concrete cover for the ferrule has to be determined using following equation.

$$c_{\min} \leq c_{\text{Ferrule}} \leq 2 \times c_{\min}$$

(EN 1992-1-1 part 4 a. Tab. 4.4N)
(EN 1992-1-1/NA Tab. NA.4.4)

STORAGE OF CAST-IN LIFTING HOOPS

Cast-in lifting hoops shall be stored in a clean, dry and aerated area, without contact to acids, bases or corrosive elements.

CONCRETE

All concrete strengths given in tables 2, 3 and 5 are cube strengths at the time of the first lifting.

PHILIPP Cast-in lifting hoop

CAST-IN LIFTING HOOPS IN BEAMS AND CONCRETE ELEMENTS SIMILAR TO WALLS

ELEMENT THICKNESSES, CENTRE AND EDGE DISTANCES

The installation and position of Cast-in lifting hoops in precast concrete elements require minimum dimensions and centre/edge distances for a safe load transfer. Given unit thicknesses d in table 2 cover axial and diagonal loading. Reduced unit thicknesses d_{red} are valid for a concrete strength f_{cc} of **30 N/mm²** and higher. When the Cast-in lifting hoop is installed it must be considered that the values e and f comply with table 2.

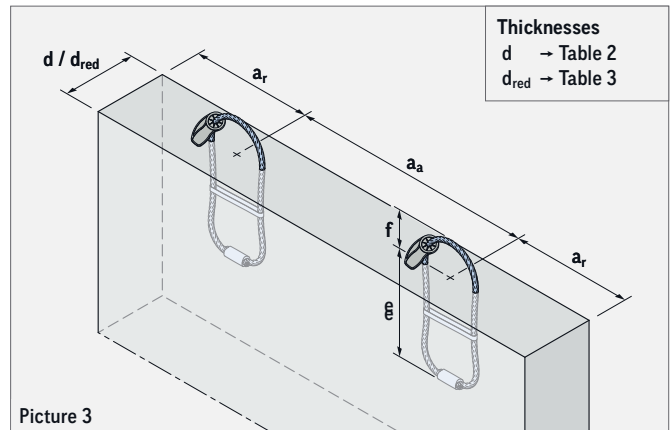

Picture 3

PERMISSIBLE LOAD DIRECTIONS

Cast-in lifting hoops can be used only for axial and diagonal tension $\beta \leq 30^\circ$.



NO LATERAL TENSION!

Lateral tension is not allowed within the whole transport chain! This also applies to a diagonal tension with angle β more than 30° !

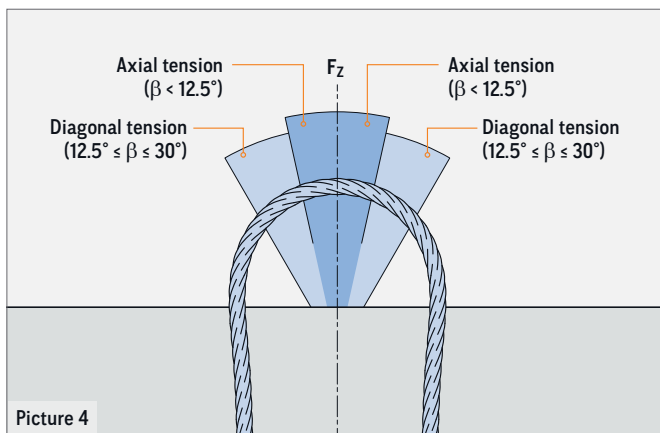

Picture 4

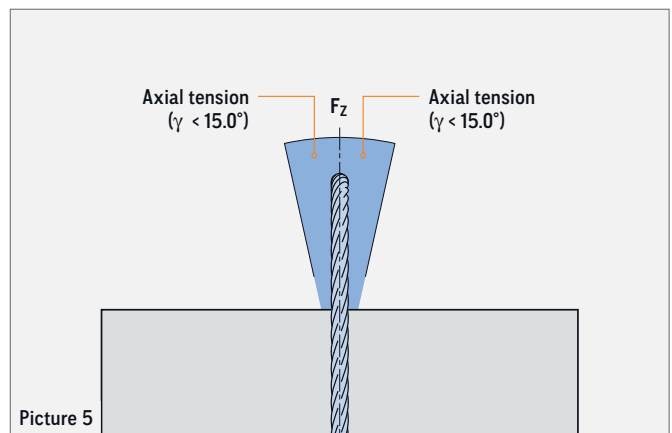

Picture 5

TABLE 2: PERMISSIBLE LOAD BEARING CAPACITIES FOR THICKNESS d FOR CONCRETE STRENGTHS f_{cc} 15 / 20 / 25 N/mm²

Load class	Element thicknesses, centre and edge distances			Embedded depth		Perm. F if f_{cc} 15 N/mm ²		Perm. F if f_{cc} 20 N/mm ²		Perm. F if f_{cc} 25 N/mm ²	
	d (mm)	a_a (mm)	a_r (mm)	e (mm)	f (mm)	Axial-tension perm. F_z 0° - 12.5° (kN)	Diagonal-tension perm. F_z 12.5° - 30° (kN)	Axial-tension perm. F_z 0° - 12.5° (kN)	Diagonal-tension perm. F_z 12.5° - 30° (kN)	Axial-tension perm. F_z 0° - 12.5° (kN)	Diagonal-tension perm. F_z 12.5° - 30° (kN)
0.8	80	600	300	150	85	8.0	8.0	8.0	8.0	8.0	8.0
1.2	90	640	320	160	75	12.0	11.8	12.0	12.0	12.0	12.0
1.6	100	660	330	165	70	13.2	11.8	15.3	12.4	16.0	13.8
2.0	110	800	400	200	70	15.9	12.9	18.4	14.9	20.0	16.6
2.5	120	920	460	230	80	21.2	18.6	24.4	21.5	25.0	24.1
4.0	200	960	480	240	100	32.9	26.6	38.0	30.8	40.0	34.4
5.2	250	1040	520	260	105	43.5	35.2	50.2	40.7	52.0	45.5
6.3	300	1120	560	280	100	62.0	51.0	63.0	58.9	63.0	63.0
8.0	380	1280	640	320	120	75.4	61.1	80.0	70.6	80.0	78.9
10.0	460	1560	780	390	125	100.0	81.6	100.0	94.2	100.0	100.0
12.5	560	1680	840	420	150	125.0	125.0	125.0	125.0	125.0	125.0
16.0	620	1800	900	450	155	149.4	125.0	160.0	139.7	160.0	156.2
20.0	680	2200	1100	550	180	178.0	144.2	200.0	166.5	200.0	186.2
25.0	750	2320	1160	580	200	223.8	228.1	250.0	250.0	250.0	250.0

- To determine the correct type please refer also to our General Installation Instruction.

- The weight of 1.0 t corresponds to 10.0 kN.

CAST-IN LIFTING HOOPS IN BEAMS AND CONCRETE ELEMENTS SIMILAR TO WALLS

TABLE 3: PERMISSIBLE LOAD BEARING CAPACITIES FOR THICKNESS d_{red} FOR CONCRETE STRENGTHS f_{cc} 30 / 35 / 45 N/mm²

Load class	Element thicknesses. centre and edge distances			Embedded depth		Perm. F if f_{cc} 30 N/mm ²		Perm. F if f_{cc} 35 N/mm ²		Perm. F if f_{cc} 45 N/mm ²	
	d_{red} (mm)	a_a (mm)	a_r (mm)	e (mm)	f (mm)	Axial-tension perm. F_Z 0° - 12.5° (kN)	Diagonal-tension perm. F_Z 12.5° - 30° (kN)	Axial-tension perm. F_Z 0° - 12.5° (kN)	Diagonal-tension perm. F_Z 12.5° - 30° (kN)	Axial-tension perm. F_Z 0° - 12.5° (kN)	Diagonal-tension perm. F_Z 12.5° - 30° (kN)
0.8	60	600	300	150	85	8.0	8.0	8.0	8.0	8.0	8.0
1.2	60	640	320	160	75	12.0	12.0	12.0	12.0	12.0	12.0
1.6	80	660	330	165	70	14.7	12.0	15.9	12.9	16.0	14.6
2.0	90	800	400	200	70	18.2	14.7	19.6	15.9	20.0	18.0
2.5	100	920	460	230	80	21.8	21.3	23.6	23.0	25.0	25.0
4.0	150	960	480	240	100	34.0	27.5	36.7	29.7	40.0	33.7
5.2	190	1040	520	260	105	45.4	36.8	49.0	39.7	52.0	45.0
6.3	220	1120	560	280	100	63.0	61.6	63.0	63.0	63.0	63.0
8.0	270	1280	640	320	120	72.6	61.6	78.4	63.5	80.0	72.0
10.0	330	1560	780	390	125	98.0	79.4	100.0	85.8	100.0	97.2
12.5	390	1680	840	420	150	125.0	125.0	125.0	125.0	125.0	125.0
16.0	430	1800	900	450	155	139.1	125.0	150.3	125.0	160.0	138.0
20.0	480	2200	1100	550	180	169.9	137.6	183.5	148.6	200.0	168.5
25.0	530	2320	1160	580	200	250.0	250.0	250.0	250.0	250.0	250.0

- To determine the correct type please refer also to our General Installation Instruction.
- The weight of 1.0 t corresponds to 10.0 kN.
- Permissible load bearing capacities for a concrete strength of f_{cc} 40 N/mm² can be interpolated.

REINFORCEMENT

For the installation of Cast-in lifting hoops in elements similar to panels and beams a minimum reinforcement near surface acc. to table 4 is needed.

This minimum reinforcement can be replaced by comparable reinforcement bars. Should it be necessary to cut single bars for the installation of Cast-in lifting hoops these have to be replaced by bars of the same diameter, strength and enough lap length according to EC 2.

At the first time of lifting the concrete must have a minimum strength f_{cc} acc. to table 2 or table 3. The user is personally responsible for further transmission of load into the concrete unit.

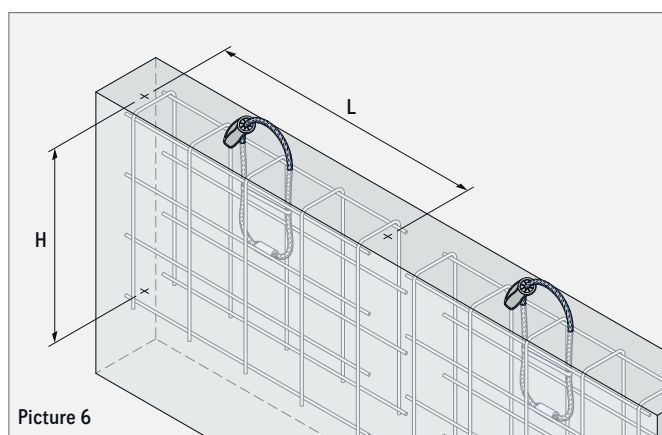

ADDITION EXISTING REINFORCEMENT!

Existing static or constructive reinforcement can be taken into account for the minimum reinforcement according to table 4.

TABLE 4: MINIMUM REINFORCEMENT NEAR SURFACE

Load class	Mesh reinforcement (square) (mm ² /m)	L (mm)	H ② (mm)
0.8	1 × 188 (mittig)	600	710
1.2	1 × 188 (mittig)	640	720
1.6	2 × 188	660	725
2.0	2 × 188	800	760
2.5	2 × 188	920	790
4.0	2 × 188 ①	960	800
5.2	2 × 188 ①	1040	820
6.3	2 × 188 ①	1120	840
8.0	2 × 188 ①	1280	880
10.0	2 × 188 ①	1560	950
12.5	2 × 257 ①	1680	1080
16.0	2 × 524 ①	1800	1390
20.0	2 × 524 ①	2200	1490
25.0	2 × 524 ①	2320	1520

① Mesh reinforcement installed in a double-bended form.

② Required H at f_{cc} 15 N/mm². H can be reduced, if the required anchorage length of the reinforcement acc. to EC 2 will be chosen longer than the embedded depth e.

PHILIPP Cast-in lifting hoop

CAST-IN LIFTING HOOPS FOR NARROW BEAMS

ELEMENT THICKNESSES, CENTRE AND EDGE DISTANCES

The installation and position of Cast-in lifting hoops in narrow beams require minimum dimensions and centre/edge distances for a safe load transfer. Thicknesses given in table 5 cover the axial and diagonal tension and can be used only for the parallel installation of Cast-in lifting hoops (picture 7).

When installing the Cast-in lifting hoop it must be considered that the values e and f comply with table 5.

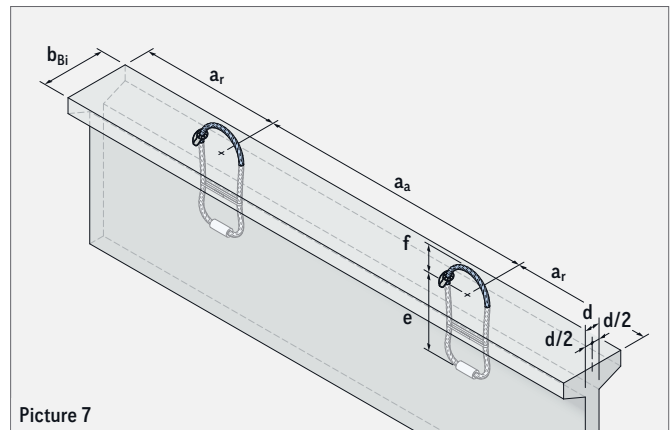

Picture 7

TABLE 5: PERMISSIBLE LOAD BEARING CAPACITIES

Load class	Element thicknesses, centre and edge distances				Embedment depth		Perm. F if $f_{cc} 25 \text{ N/mm}^2$	Perm. F if $f_{cc} 30 \text{ N/mm}^2$
	d (mm)	b_{Bi} (mm)	a_a (mm)	a_r (mm)	e (mm)	f (mm)	Axial tension / diagonal tension perm. F_z 0°-30° (kN)	Axial tension / diagonal tension perm. F_z 0°-30° (kN)
16.0	120	≥ 400	2000	1400	450	165	160.0	160.0
20.0	120	≥ 400	2000	1400	550	180	200.0	200.0
25.0	120	≥ 400	2000	1400	600	180	246.5	250.0

- To determine the correct type please refer also to our General Installation Instruction.
- The weight of 1.0 t corresponds to 10.0 kN.

PERMISSIBLE LOAD DIRECTIONS

Cast-in lifting hoops can only be used for axial and diagonal tension up to 30°.



NO LATERAL TENSION!

Lateral tension is not allowed within the whole transport chain! This also applies to a diagonal tension with angle β more than 30°!

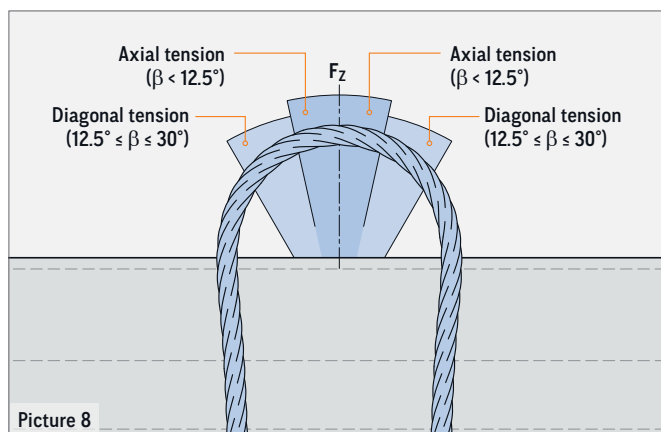

Picture 8

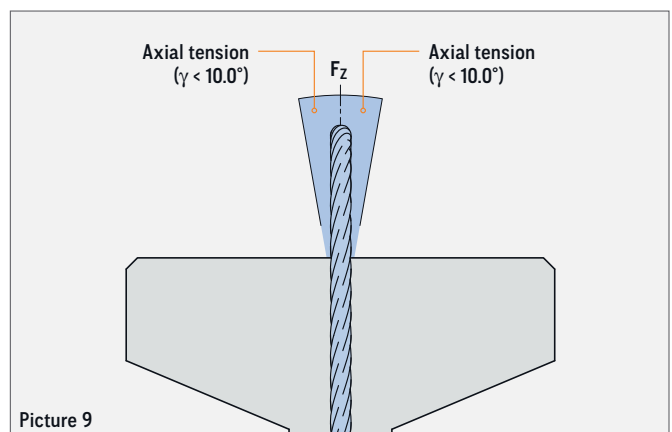

Picture 9

CAST-IN LIFTING HOOPS FOR NARROW BEAMS

REINFORCEMENT

For the installation of Cast-in lifting hoops in beams the precast elements must be reinforced with a minimum reinforcement (picture 10). Should it be necessary to cut single bars for the installation of Cast-in lifting hoops these have to be replaced by bars of the same diameter, strength and enough lap length according to EC 2. At the first time of lifting the concrete must have a minimum strength f_{cc} of **25 N/mm²**.

The user is personally responsible for further transmission of load into the concrete unit.



ADDITION EXISTING REINFORCEMENT!

Existing static or constructive reinforcement can be taken into account for the minimum reinforcement according to table 10.

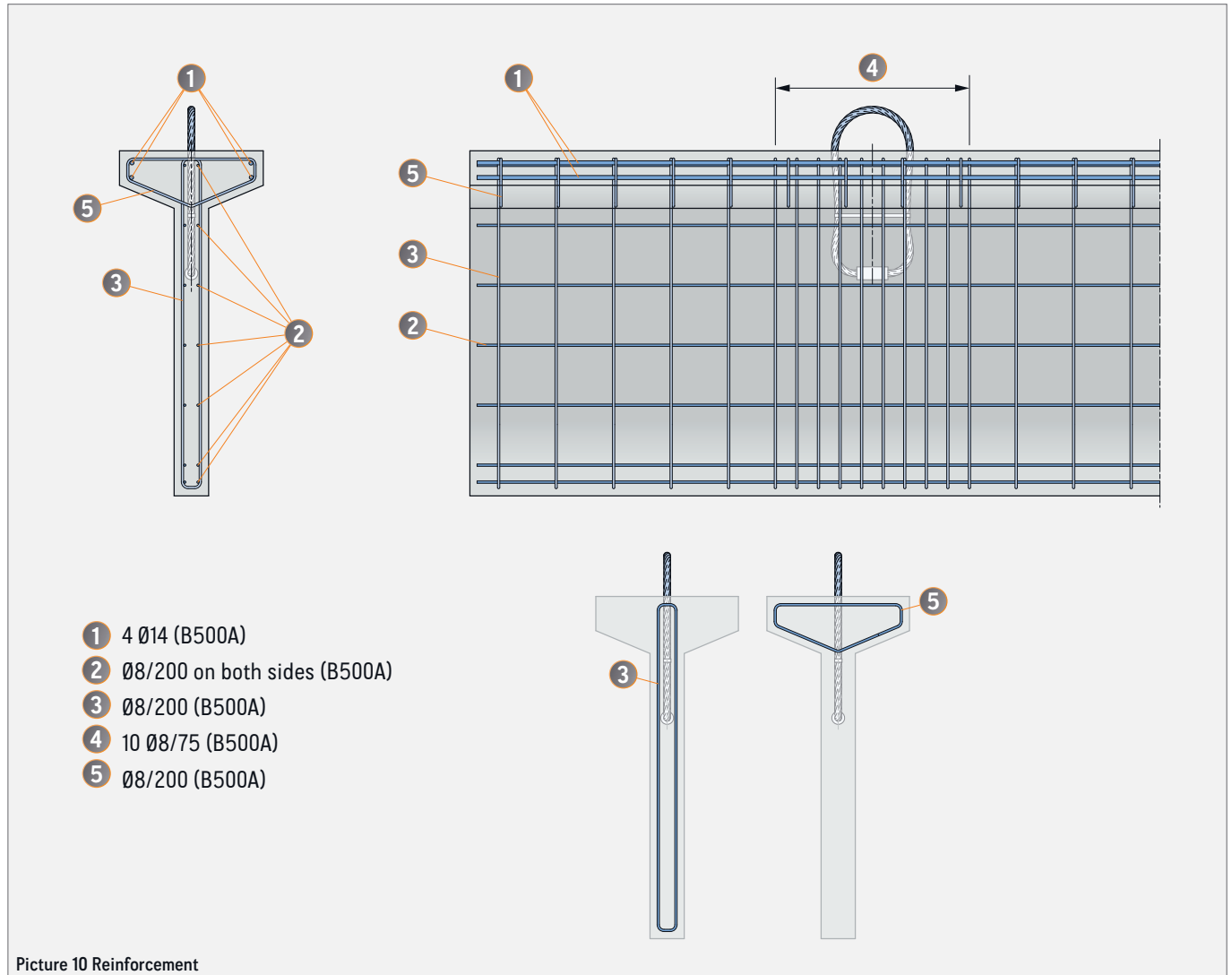

PHILIPP Cast-in lifting hoop

INSTALLATION / SAFETY

INSTALLATION

If Cast-in lifting hoops are installed in an open side of a mould (picture 11) it must be fixed carefully to the reinforcement so that the embedment depth is guaranteed.

For the installation on a side of the mould a slot hole is needed (picture 12). After installation of the Cast-in lifting hoop the slot hole must be closed accurately in order to avoid the Cast-in lifting hoop to be moved in a false position. In order to guarantee the position of the Cast-in lifting hoop during concreting and compacting it must be fixed to the reinforcement. It might be necessary to add some more steel bars to ensure the right position. Here attention has to be paid not to place those steel bars directly over the ferrule of the hoop.

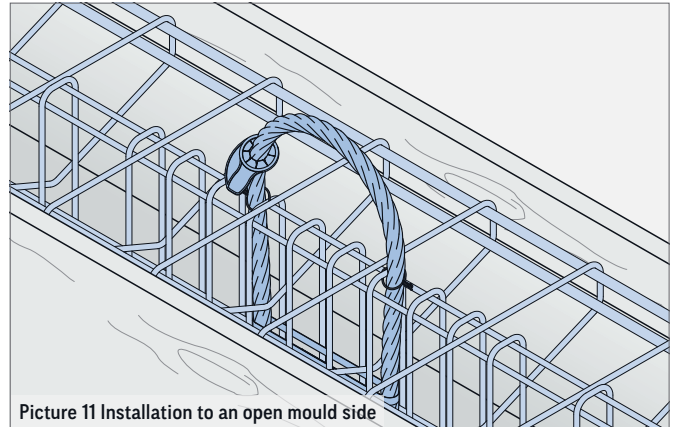

Picture 11 Installation to an open mould side

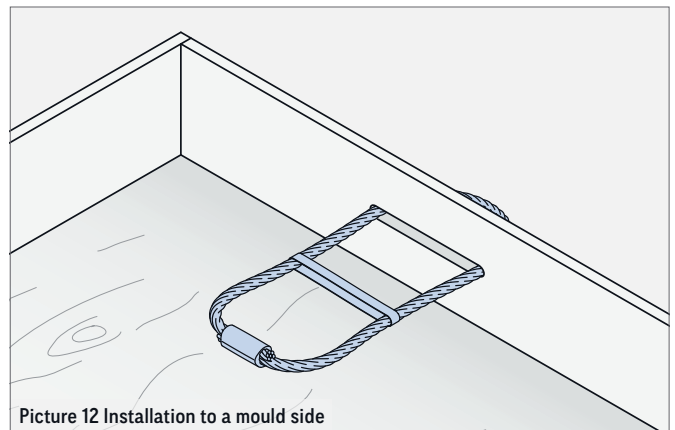

Picture 12 Installation to a mould side

WELDING!

Welding or other strong heat influences on the lifting hoops are not allowed.

SAFETY NOTICES

By using too small, too large or sharp-edged hooks the lifetime of the transport anchor will be reduced. The transition radii of used hooks must be at least 1.75 times of the wire rope diameter of the Cast-in lifting hoop (picture 13).

Using a shackle the pin must be at least 3.5 times of the wire rope diameter of the Cast-in lifting hoop (picture 14).

During use of Cast-in lifting hoops the following must be considered:

- » The use of damaged Cast-in lifting hoops with broken strands, contusions, kinks or corrosion pits is not allowed.
- » Contact of Cast-in lifting hoops with acids or alkalis must be avoided.
- » Misuse of Cast-in lifting hoops because of wrong load directions must be also avoided.
- » Lever arms caused by rotating, tilting and swinging which result in local blow-out failures in the concrete or broken wire ropes are inadmissible!

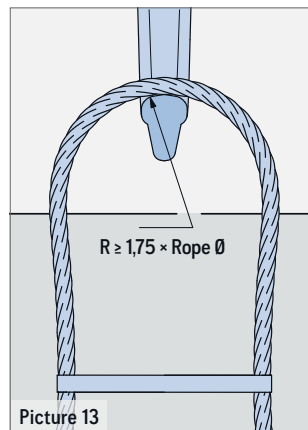

Picture 13

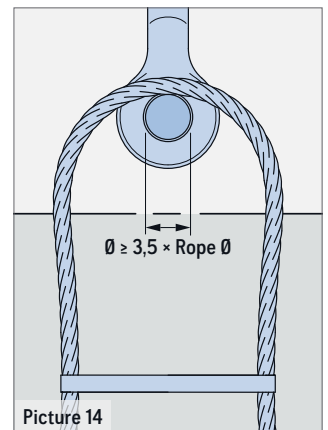

Picture 14

TRANSITION RADIUS

In order to guarantee the correct transition radius we recommend to use our special Wire protection pulley. This is available in six dimensions for all our Cast-in lifting hoops from load class 0.8 up to 95.0.

For more details please refer to the separate data sheet of the Wire protection pulley.



SAFETY

STORAGE OF THE PRECAST UNITS

During storage of the concrete units please make sure that the Cast-in lifting hoops are not bent in any way. This can be guaranteed by using a spacer (e.g. a squared timber) between the concrete elements.

An outdoor storage of the concrete units can lead to corrosion and as a result to a reduction of the bearing capacity.

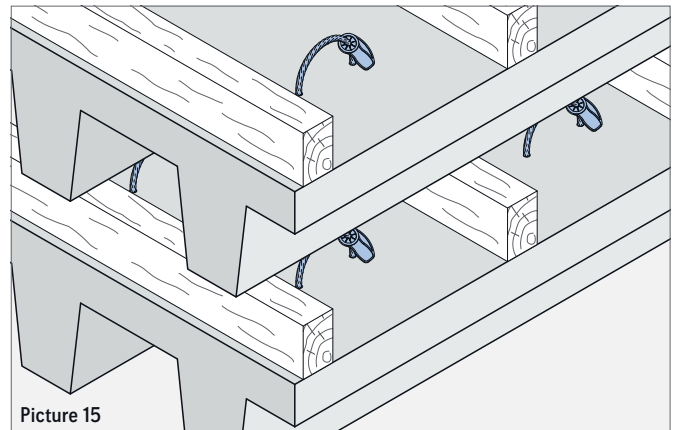

Picture 15



SIGNIFICANT CORROSION!

If a significant corrosion appears to the installed Cast-in lifting hoops they cannot be used for lifting anymore.

HEADQUARTERS

Lilienthalstraße 7-9
63741 Aschaffenburg

☎ +49 6021 40 27-0

✉ info@philipp-gruppe.de

PRODUCTION AND LOGISTICS

Hauptstraße 204
63814 Mainaschaff

☎ +49 6021 40 27-0

✉ info@philipp-gruppe.de

OFFICE COSWIG

Roßlauer Straße 70
06869 Coswig / Anhalt

☎ +49 34903 6 94-0

✉ info@philipp-gruppe.de

OFFICE NEUSS

Sperberweg 37
41468 Neuss

☎ +49 2131 3 59 18-0

✉ info@philipp-gruppe.de

OFFICE TANNHEIM

Robert-Bosch-Weg 12
88459 Tannheim / Allgäu

☎ +49 8395 8 13 35-0

✉ info@philipp-gruppe.de

PHILIPP VERTRIEBS GMBH

Pfaffing 36
5760 Saalfelden / Salzburg

☎ +43 6582 7 04 01

✉ info@philipp-gruppe.at



HEADQUARTERS Aschaffenburg



Visit us!

www.philipp-gruppe.de